



To be the Chief Evangelist

Ender-3 Pro Series 3D Printer

Guide Book

[To make Top-quality 3D printer]

- ◆ This guide is for the Ender-3 Pro Series of 3D printers.
- ◆ Select the correct input voltage to match your local mains (230V or 115V)
- ◆ Because of software/hardware upgrades and model differences, new revisions may not be listed in this guide.
- ◆ Please plug the power cord into a three-hole power jack.
- ◆ Detailed instructions for use are available in the TF card.

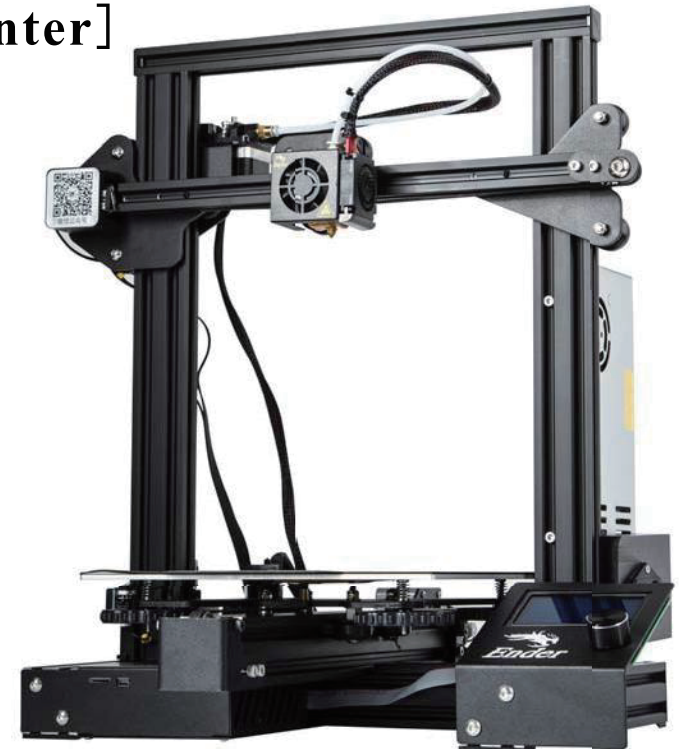

Notes

1. Do not use the Printer in any way other than described herein to avoid personal injury or property damage.
2. Do not place the Printer near flammables, explosives or heat sources. It is best to place it in a well-ventilated, low-dust environment.
3. Do not expose the Printer to violent vibration or any unstable environment. This will cause poor print quality.
4. The filaments recommended by the manufacturer are preferred as to avoid clogging in the hot end and/or Printer damage.
5. Do not use any other power cable than the one supplied. Use a grounded three-prong power outlet.
6. Do not touch the nozzle or hot bed during printing. Keep hands away from machine while in use to avoid burns or personal injury.
7. Do not wear gloves or loose clothing when operating the Printer. These loose articles can become caught in moving parts and cause personal injury or Printer damage.
8. Clean off filament from the nozzle tip with the provided pliers before the nozzle cools. Do not touch the nozzle directly. This can cause personal injury.
9. Clean the Printer frequently. With the machine powered off, clean the printer body with a dry cloth to remove dust, adhered printing materials and foreign objects on guide rails. Use glass cleaner or isopropyl Alcohol to clean the print surface before every print for consistent results.
10. Children under 10 years of age should not use the Printer without supervision.

Contents

1. Introduction	1	5. Software Installation	5
2. Screen Information.....	2	6. Preparing to Print.....	6
3. Loading Filament.....	3	7. Trouble-shooting	7
4. Bed Levelling.....	4		

Preface

Dear consumers,

Thank you for choosing our products. For the best experience, please read the instructions before operating the Printer. Our 3D team is always ready to provide you with assistance. Please contact us via the phone number or e-mail address provided at the end when you encounter any problem with the Printer.

For a better experience in using our product, you may learn how to use the Printer in the following ways:

1. View the accompanied instructions and videos in the TF card.
2. Visit our official website www.creality.com You will find relevant software/hardware information, contact details and operation and maintenance instructions on the website.

1. Introduction

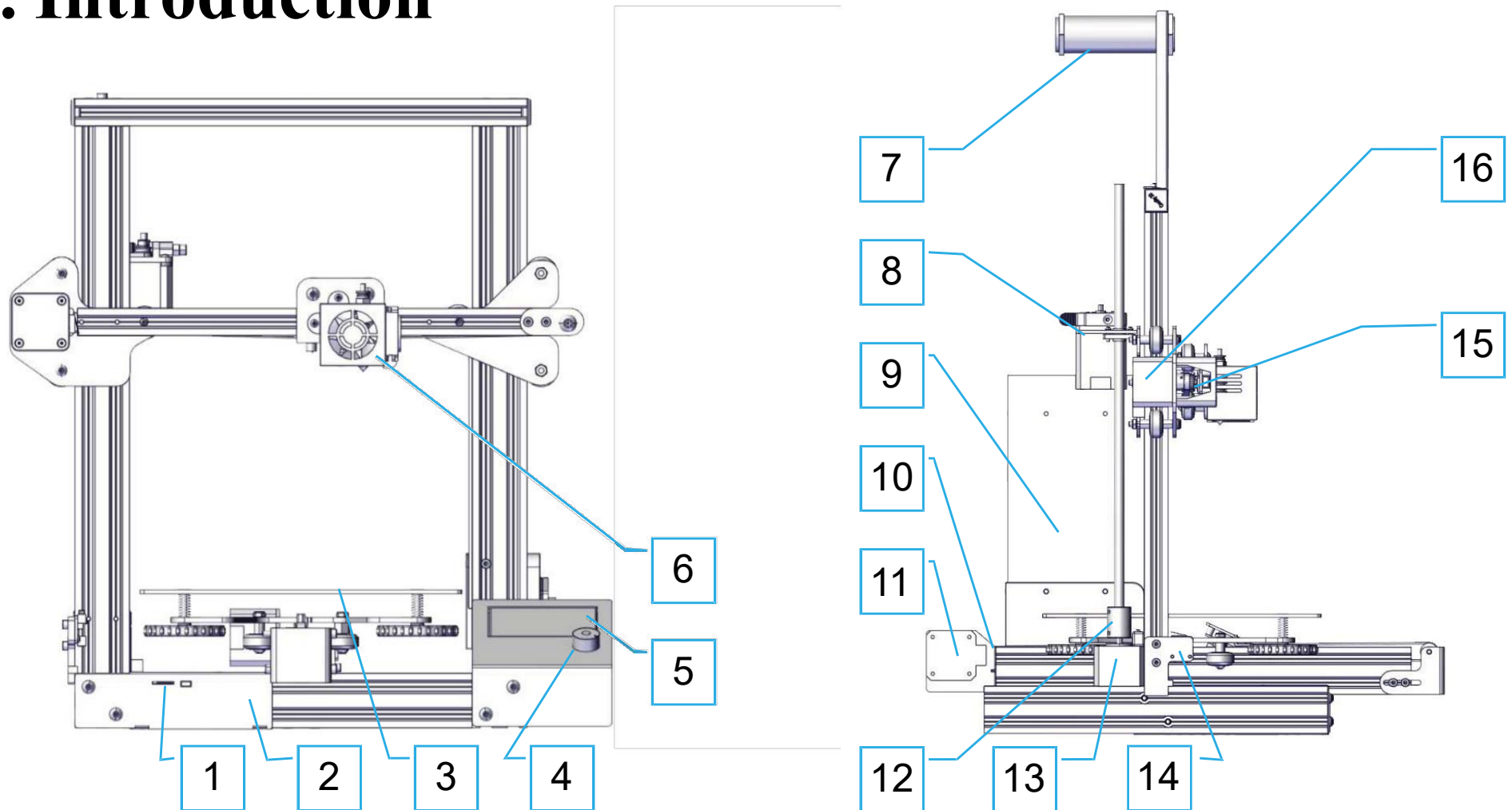

- 1. TF Slot and USB Port
- 2. Control Box
- 3. Print Surface
- 4. Control Knob

- 5. Display Screen
- 6. Nozzle Assembly
- 7. Spool Holder
- 8. Extruder (E) Stepper

- 9. Power
- 10. Y Limit Switch
- 11. Y Stepper
- 12. Coupling

- 13. Z Stepper
- 14. Z Limit Switch
- 15. X Limit Switch
- 16. X Stepper

2. Screen Information Information Displayed

Print Speed

Model

Set Temperature of the Nozzle

Current Temperature of the Nozzle

Set Temperature of the Hot Bed

Current Temperature of the Hot Bed

Part Cooling Fan Speed

Current Location of the nozzle

Print Time

Print Progress

Prompt Message

Push : OK/Enter Sub Menu
Turn : Change Option/Value

Screen Options		
Menu	Sub Menu	Explanation
↑ Info Screen ↑	↑ main ↑	Return
Prepare →	Disable Steppers	Moving X Y Z axis by your hands
	Auto Home	return to the origin
	Preheat PLA	
	Preheat ABS	
	Cooldown	Close and cooldown the nozzle
Control →	Move Axis →	Moving X Y Z axis or Extruder by given value.
	Temperature →	Heat the nozzle and the bed or change fan speed by given value
No card /Print from SD		Select the printing model
Init. SD-Card /Change SD-Card		Restore factory setting
Printing		
Tune →	Speed	Change Printing Speed by given value
	Nozzle	Change the temperature by given value
	Bed	Change the temperature by given value
	Fan Speed	Change Fan Speed by given value
	Flow	Change filament flow by given value
Pause Print		
Stop Print		

3. Loading Filament

1. Preheat

Method 1

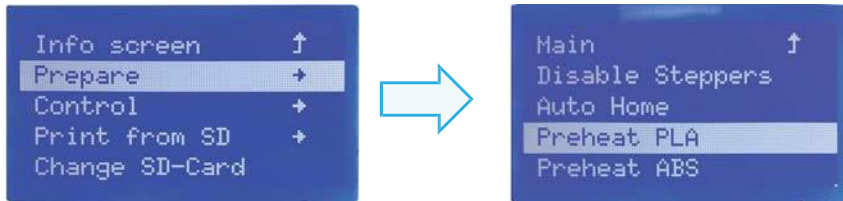

Method 2

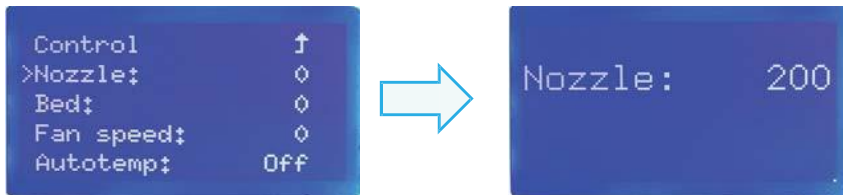
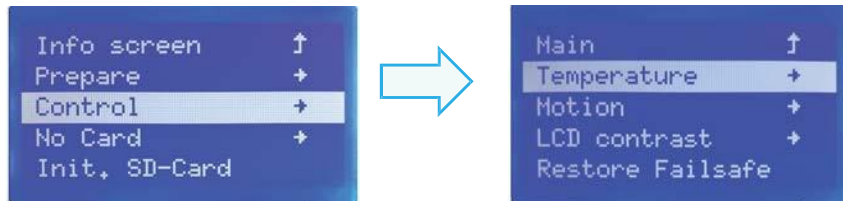

2. Feeding

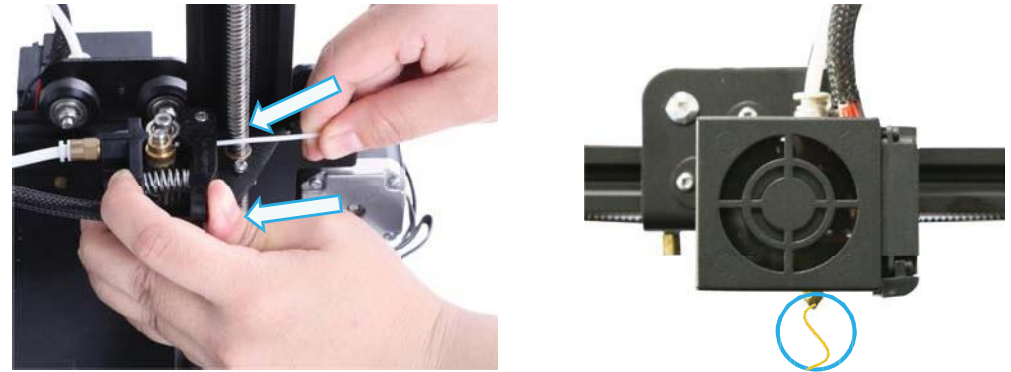

Press and hold the extruder lever then insert 1.75mm filament through the small hole of the extruder. Continue feeding until you see filament come out the nozzle.

Tip : How to Replace the Filament?

1s Cutting filament near the Extruder and slowly feed new filament until they are fed into the new filament.

2s Preheating the nozzle and withdraw the filament quickly and feed the new filament.

4. Bed Levelling

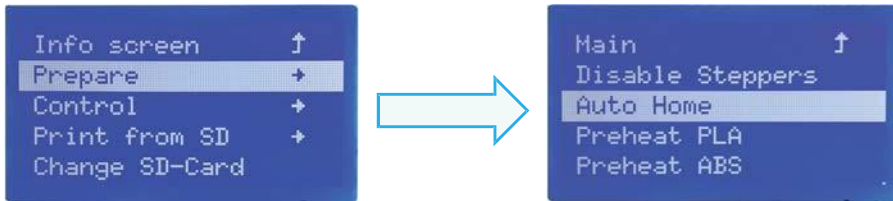

1. Prepare < Auto Home. Wait for the nozzle to move to the left/front of the platform.

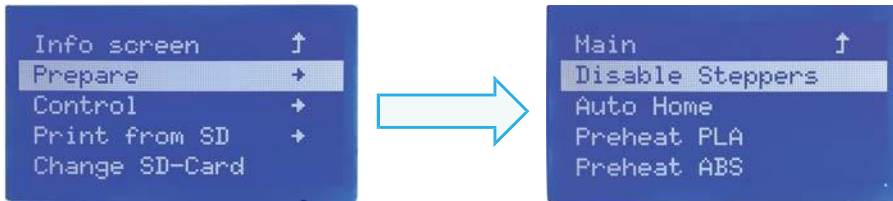

2. Prepare < Disable Steppers (Close stepper drive, release motor)

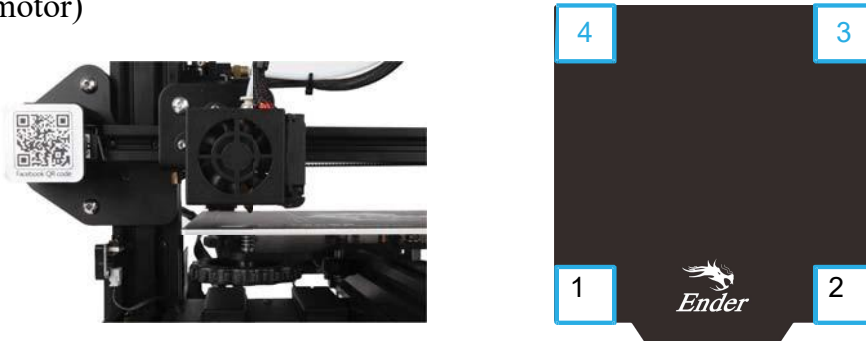

3. Move the nozzle the front/left leveling screw and adjust the platform height by turning the knob underneath. Use a piece of A4 paper (standard printer paper) to assist with the adjustment, making sure that the nozzle lightly scratches the paper.

4. Complete the adjustment of the screw on all 4 corners.

5. Repeat above steps 1-2 times if necessary.

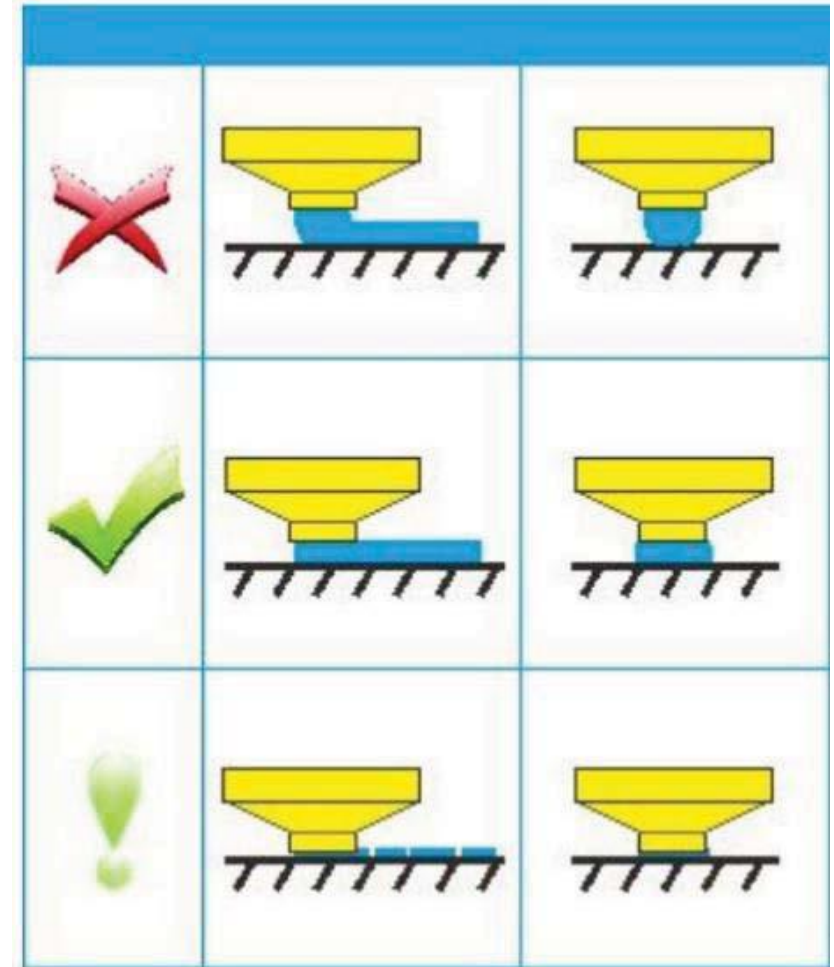

5. Software Installation



Creality
Slicer_1.2.3

1. Double click to install the software.



Creality Slicer

2. Double click to open the software.

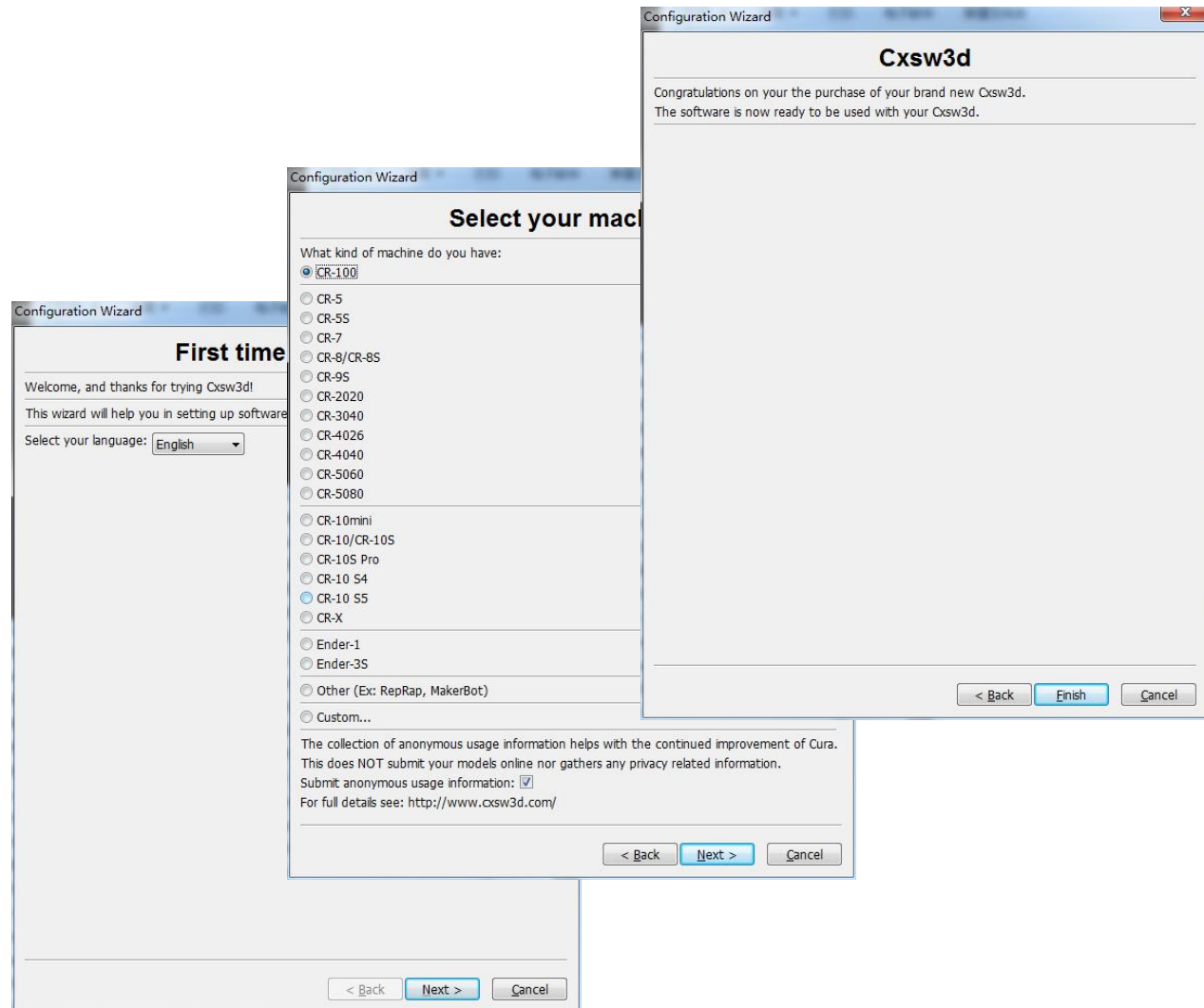

3. Select language→Next→Select your machine→Next→Finish.

6.For the first Printing

1.Slicing

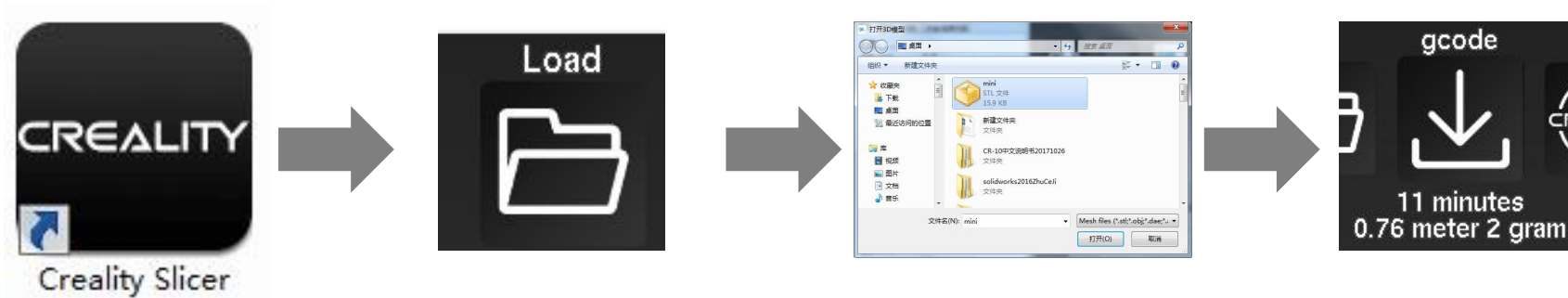

Open the software→Load→Select the file→Wait for slicing to finish ,and save the gcode file to TF card.

2.Printing

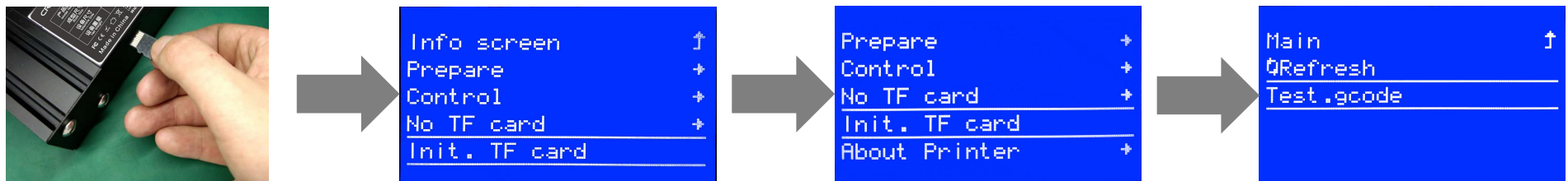

Insert the TF card→ Print → Select the file to be printed.

7. Trouble shooting

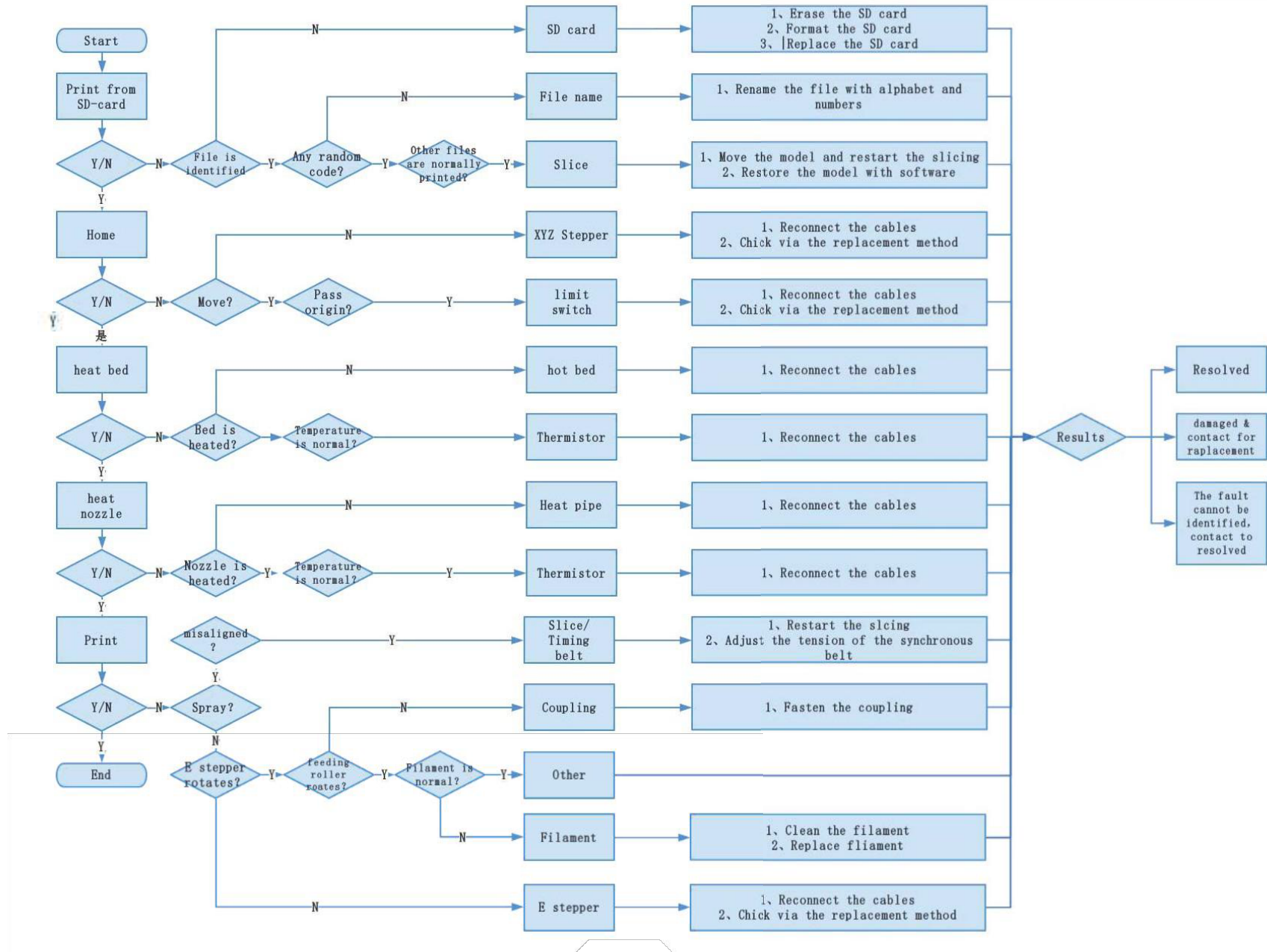

After- Sales Service

Service

1, The printer can be returned within seven days, 15 days replacement, one year warranty, lifetime maintenance.

Replacement requirement

1. The appearance of the product is intact, without damage, scratches, smudges, cracks, deformation, etc.;
2. Machine parts, tools and others are complete;
3. Provide a complete and valid purchase invoice and warranty, product number should be the same.

Warranty coverage

1. The following accessories are not included in the warranty coverage if they are not damaged by transportation: platform sticker; platform forming plate; acrylic cover; card reader and TF card; platform glass; USB cable; filament; rack and tools,etc.
2. Profile: Before we deliver the goods, we will do the machine test, so maybe there will be light scratch, or due to long-distance transportation, which scratch the profile a little bit. in the premise of not affecting the normal use, in principle, not within the scope of warranty;
3. Nozzle assembly (nozzle, heating block, throat pipe,heat sink, Teflon tube, etc.) warranty period is 3 months, if it is damage after the warranty expires, you need to purchase another one;
4. Motherboard, LCD display, power supply, hot bed,warranty period is 12 months, if there are quality problems, you can get free maintenance; over the warranty period, can be sent back to the original factory maintenance, the users need to bear the return shipping and maintenance costs;
5. Not included in warranty coverage:
 - (1) It is not possible to provide an effective after-sales service card or serial number;
 - (2) The whole machine and components exceed the warranty period;

- (3) Equipment failure or damage caused by unauthorized modification of the equipment (private modification includes: 1. modification of the nozzle assembly; 2. modification of the machine structure; 3. use of third-party components; 4. use of third-party firmware procedures or change the original Factory firmware program, etc.);
- (4) Equipment failure or damage due to incorrect installation and use;
- (5) Equipment failure or damage caused by the use of the equipment in a working environment not specified by the product;
- (6) Equipment failure or damage due improper use (beyond workload, etc.) or maintenance (moisture, etc.);
- (7) Equipment failure or damage due to the use of other branded components or low quality consumables.

Statement:

For better highlighting the function and effectiveness of 3d printer and promoting the development of global market economic, strengthening the user self-discipline of 3d industry and establishing a good image of 3d printing, since Creality 3d printer have passed all kinds of authorized product certificates and quality management system.hereby we declare that it is strictly forbidden to use our printer to print any products or equipment that are in violation of the specific country and regions legislation.

The revision date: March 20, 2020



SHENZHEN CREALITY 3D TECHNOLOGY CO.,LTD.
11F & Room 1201,Block 3,JinChengYuan,Tongsheng Community,Dalan
g,Longhua District,Shenzhen,China,518109
Official Website: www.creality.com
Tel: +86 755- 85234565
E- mail: info@creality.com cs@creality.com

